

VT-01

**Secondary Surveillance Radar
Transponder Mode-S**

Installation Manual

1. Table of Contents

Record of Revisions	2
1. Table of Contents	3
2. Preface:	5
3. Unpacking and part identification	5
3.1. VT-01:	5
3.2. VT-01 UltraCompact	6
4. Input Devices (human machine interface)	7
4.1. On/Off key	7
4.2. Ident key	7
4.3. Mode-key	7
4.4. Double shaft rotary encoder	7
5. Technical data and specifications	8
5.1. General	8
5.2. Certification base	9
5.3. Equipment class	10
5.4. Mode-S transponder level	10
5.5. Equivalences to FAA TSO-C112 Classes:	10
5.6. Limitations	10
5.7. Environmental categories	11
5.7.1. VT-01	11
5.7.2. VT-01 UltraCompact	12
5.8. Software level	13
5.9. Telecommunication specifications	13
5.10. Logic of on-Ground interface	13
5.11. CAN-Bus interface	13
6. Aircraft installation	14
6.1. Installation VT-01 - single-block	14
6.1.1. Assembling the steering unit and central unit:	14
6.1.2. Panel mounting	15
6.1.3. Static pressure connection	15
6.1.4. Wiring	16
6.2. Installation VT-01 - two-block	19
6.2.1. Installing the mounting kit / cradle	20
6.2.2. Panel mounting	20
6.2.3. Static pressure connection	20
6.2.4. Wiring	21
6.2.5. Cradle handling	25
6.3. Installation VT-01 UltraCompact	27
6.3.1. Panel mounting	27
6.3.2. Static pressure connection	27
6.3.3. Wiring	27
7. Antenna installation	30
7.1. General	30
7.2. Special instructions for antenna installation in composite aircraft	30
7.2.1. Mounting Preparation	30
7.2.2. Ground Plane Size	30
8. Antenna cable	31
9. Post installation configuration and setup	32
9.1. Setting up pilot specific data	32

9.1.1. Flight ID / aircraft registration	32
9.1.2. Display contrast	33
9.1.3. Display illumination	33
9.2. Setting up password protected data	34
9.2.1. Illumination	34
9.2.2. LCD contrast	34
9.2.3. Power-up Mode	34
9.2.4. Aircraft data	35
10. Determining installed equipment performance	38
10.1. Checking equipment installation	38
10.2. Equipment performance	38
10.3. Flight test procedures	40
10.3.1. General	40
10.3.2. Flight tests instructions	40
11. Instructions for continued airworthiness	41
Appendix A - Dimensions	42
VT-01 Steering unit and System unit	42
VT-01 Mounting kit (with cradle)	43
VT-01 UltraCompact	44
Appendix B	45
Appendix C	46
Assembling BNC/TNC plugs for AIRCELL 7 coaxial cable	46
Assembling the Sub-D Connectors for interconnection wiring	47



2. Preface:

This manual contains installation information and instructions for the Mode-S transponder VT-01. It shall be read before installing your VT-01 transponder.

The installation shall be carried out or supervised by a qualified person. Damage caused by installation by unqualified persons is not covered by the manufacturers warranty.

Safety symbols:

The following symbols and terms are used in this manual:

	<p>Warning <i>Warning statements identify conditions or practices that could result in injury or loss of life</i></p>
	<p>Caution <i>Caution statements identify conditions or practices that could result in damage of this product or other property.</i></p>
	<p>Important note: <i>Indicates important or usefull information. It is strongly recommended to read, understand and follow the statement.</i></p>

3. Unpacking and part identification

3.1. VT-01:

The VT-01 transponder system is supplied with the following:

P/N:	VT-0101-()-()-()	Steering unit
P/N:	VT-0102-()-()-()-070	Central unit Class 2 (71 Watt)
or	VT-0102-()-()-()-125	Central unit Class 1 (125 Watt)

Document:	01.0200.10	User's guide
Document:	01.0200.11	Installation manual (this document)

Available options:

P/N: VT-0103-1-()-()	Mounting kit/wiring harness with installation cradle (required for installation of VT-01 as a two block system with remote steering unit. It also allows simple and quick installation and removal of the central unit. VT-01UC cannot be installed as two block systems).
----------------------	--

P/N:	VT-0103-2-()-()	Mounting kit/wiring harness without installation cradle
------	-----------------	---

Document:	01.0200.12	Maintenance and repair manual (for avionics repairshops only)
-----------	------------	---

3.2. VT-01UltraCompact

The VT-01 UltraCompact transponder system is supplied with the following:

P/N	VT-0104-125	System unit
	or	VT-0104-070
P/N:	VT-0103-2-()-()	Mounting kit/wiring harness without installation cradle

Available options:

Document:	01.0200.12	for maintenance and repair manual (for avionic repairshops only)
-----------	------------	--

4. Input Devices (human machine interface)

Picture of front panel with Input devices

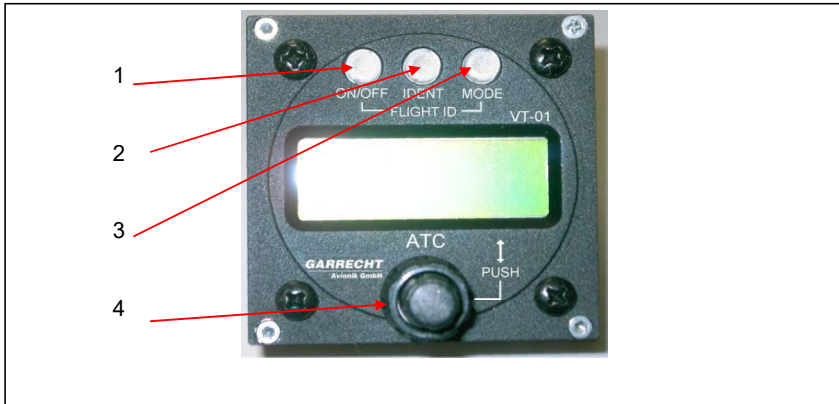

The system will be operated using the following devices:

Nr.	Description	Function
1	On/Off key	Switches the system On or Off
2	Ident – key	Invokes the Ident Mode for 18 sec.
3	Mode – key	Selects the operating mode
4	Double shaft encoder with push on capability for inner knob	Enters or modifies values

4.1. On/Off key

To enable the system, press key 1 shortly. After the start, the unit performs the built in test and shows the operating mode. For switching off, press key 1 for at least 3 seconds. Release the key, when the LCD becomes blank

4.2. Ident key

Pressing key 2 invokes the ident mode for 18 seconds. Use this function only when the ATC requires to sqawk ident.

4.3. Mode-key

Key 3 selects the following modes:

- SBY Standby - System is switched on, no replies or squitters will be sent.
- ON Selected reply code will be replied for Mode-A/C interrogations, altitude information is set to zero, squittering is enabled, Mode-S interrogations will be replied
- ALT Selected reply code will be replied for Mode-A/C interrogations, altitude information is set to indicated value, squittering is enabled, Mode-S interrogations will be replied

4.4. Double shaft rotary encoder

Main input device for setting values is the double shaft rotary encoder. Rotating the outer knob selects the position to be modified. Rotating the inner knob changes the selected value.

The edit mode will be started rotating the inner or outer knob of the double shaft encoder.

Pushing the inner knob confirms the selected value and cancels the edit mode (cursor stops blinking).

5. Technical data and specifications

5.1. General

Technical characteristics	Data
Mechanical VT-01 Dimensions Mounting Weights VT-01 UltraCompact Dimensions Mounting Weight	Steering unit :65x65x34,5 mm (w/o. connectors) Central unit: 65x65x128 mm (w/o. connectors) 57 mm panel mount Steering unit: 0,21 kg Central unit: 0,61 kg 61,5 x 61,5 x 170mm 57 mm panel mount 0,57 kg
Environmental Max. Altitude Temperature Cooling Vibration Shock	50.000 ft (internal alticoder limited to 40.000ft) (see also limitations chap. 5.6) -20°C - +55°C passive, no auxiliary cooling required DO160D Cat. S, Curve M Operational: 6g, crash safety: 20g
Electrical Voltage (nom.): Voltage (operational) Current (nom.) @ 13,8 V and 1200 A/C replies/sec. Standby (squitters active) RF-power @ antenna Replyrate: Output Impedance max. VSWR	13,8 V DC 9 to 32 V DC VT-0102-()-()-070 VT-0104-070: 0,35 A VT-0102-()-()-125 VT-0104-125: 0,45 A VT-0102-()-()-070 VT-0104-070: 0,16 A VT-0102-()-()-125 VT-0104-125: 0,17 A VT-0102-()-()-070 VT-0104-070: > 70 Wp VT-0102-()-()-125 VT-0104-125: > 125 Wp min. 1200/s Mode-A/C min. 50/s Mode-S 50 Ohms 1,5:1

<p>Interfaces:</p> <p>Human machine interface / User input capability</p>	<p>The system provides 3 buttons and a twinaxle rotary encoder for inputting values and selecting operational modes. System messages and entered values are displayed on a 2 lines / 12 characters LCD display.</p>										
<p>Automatic input capability:</p> <p>On Ground interface:</p>	<p>The system detects the input of an "on ground" switch. If the aircraft's frame does not supply such an information, the input channel will be set to "airborne" always (ref. to chapter 5.10).</p> <p>Logic = 0: on ground condition</p>										
<p>Suppression interface:</p>	<p>The system provides an suppression interface to prevent interference with other instruments installed in the same aircraft (such as DME):</p> <p>Impedances:</p> <table data-bbox="644 598 940 662"> <tr> <td>DC: -0,4 V to + 30 V:</td> <td>7,2 kOhms</td> </tr> <tr> <td>DC: < -0,4 V:</td> <td>1 kOhms</td> </tr> <tr> <td>AC:</td> <td>1 kOhms</td> </tr> </table> <p>Levels:</p> <table data-bbox="644 710 800 758"> <tr> <td>output:</td> <td>10 V</td> </tr> <tr> <td>input:</td> <td>7 V - 30 V</td> </tr> </table>	DC: -0,4 V to + 30 V:	7,2 kOhms	DC: < -0,4 V:	1 kOhms	AC:	1 kOhms	output:	10 V	input:	7 V - 30 V
DC: -0,4 V to + 30 V:	7,2 kOhms										
DC: < -0,4 V:	1 kOhms										
AC:	1 kOhms										
output:	10 V										
input:	7 V - 30 V										
<p>Alitcoder capability</p>	<p>The system contains an integral digital altitcoder to provide data about pressure altitude for Mode C information in 100 ft steps. It's line has to be connected to the aircraft's static pressure system.</p> <p>Range: -1000ft to + 40.000ft</p>										
<p>Self test routines (BIT)</p>	<p>After powering on, the system runs several internal self test routines permanently. In case of errors, the user gets warned visible and audible and depending on the level of error, the system stops operating with a permanent error message.</p>										

5.2. Certification base

ETSO-2C112a
EUROCAE ED-73B

5.3. Equipment class

Class 1: If using central unit VT-0102-()-()-125
If using system unit VT-0104-125

Class 2: If using central unit VT-0102-()-()-070
If using system unit VT-0104-070

5.4. Mode-S transponder level

Level 2se Mode-S transponder

5.5. Equivalences to FAA TSO-C112 Classes:

If using central unit VT-0102-()-()-125 or
If using system unit VT-0104-125: Equal to FAA TSO C112 Class: 2A1 120 010

If using central unit VT-0102-()-()-070 or
If using system unit VT-0104-070 Equal to FAA TSO C112 Class: 2B1 020 010

5.6. Limitations

1. To reach the required minimum RF peak power, the use of an antenna cable with a total loss of less or equal 2,5 dB is required.
2. The range of the internal alticoder is limited to a maximum altitude of 40.000 ft.
3. The system using the CLASS 2 central unit (P/N: VT-0102-()-()-070) or the system unit VT-0104-070 may be operated in aircraft not exceeding a maximum speed of 175 kts, a maximum altitude of 15.000 ft and a MTOW of 5700 kg.
4. The system using the CLASS 1 central unit (P/N: VT-0102-()-()-125) or the system unit VT-0104-125 may be operated in aircraft not exceeding a maximum speed of 250 kts, a maximum altitude of 50.000 ft and a MTOW of 5.700 kg.

5.7. Environmental categories

5.7.1. VT-01

	Section	Category	Conditions
Temperature / Altitude D1	4.0	D1	
Low ground survival temperature	4.5.1	D1	-55°C
Low operating temperature	4.5.1	D1	-20°C
High ground survival Temperature	4.5.2	D1	+85°C
High Short-time Operating Temperature	4.5.2	D1	+70°C
High Operating Temperature	4.5.3	D1	+55°C
In .Flight Loss of Cooling	4.5.4	Z	No auxiliary cooling required
Altitude	4.6.1	D1	50.000 ft.*
Temperature Variation	5.0	B	5°C / minute
Humidity	6.0	A	
Shock	7.0	B	6 G operational shocks 20 G crash safety
Vibration	8.0	S	Vibration curve M
Explosion Profness	9.0	X	
Water Profness	10.0	X	
Fluids Susceptibilities	11.0	X	
Sand and Dust	12.0	X	
Fungus Resistance	13.0	X	
Salt Spray	14.0	X	
Magnetic Effect	15.0	Z	Less than 0.3 m
Power Input (DC)	16.0	B	
Voltage Spike Conducted	17.0	B	
Audio Frequency Conducted Susceptibility	18.0	B	
Induced Signal Susceptibility	19.0	A	
Radio Frequency Susceptibility	20.0	T	
Emission of RF	21.0	B	compliant with CAT M except of harmonics of 1090 MHz
Lightning Induced Transient Susceptibility	22.0	A2XXX	
Lightning Direct Effects	23.0	X	
Icing	24.0	X	
Electrostatic Discharge (ESD)	25.0	A	
* see chapter 5.6 for restrictions			

5.7.2. VT-01 UltraCompact

	Section	Category	Conditions
Temperature / Altitude D1	4.0	D1	
Low ground survival temperature	4.5.1	D1	-55°C
Low operating temperature	4.5.1	D1	-20°C
High ground survival Temperature	4.5.2	D1	+85°C
High Short-time Operating Temperature	4.5.2	D1	+70°C
High Operating Temperature	4.5.3	D1	+55°C
In-Flight Loss of Cooling	4.5.4	Z	No auxiliary cooling required
Altitude	4.6.1	D1	50.000 ft.*
Temperature Variation	5.0	B	5°C / minute
Humidity	6.0	A	
Shock	7.0	B	6 G operational shocks 20 G crash safety
Vibration	8.0	U2 R	Vibration curve F/F1 Vibration curve B/B1
Explosion Profness	9.0	X	
Water Profness	10.0	X	
Fluids Susceptibilities	11.0	X	
Sand and Dust	12.0	X	
Fungus Resistance	13.0	X	
Salt Spray	14.0	X	
Magnetic Effect	15.0	Z	Less than 0.3 m
Power Input (DC)	16.0	B	
Voltage Spike Conducted	17.0	B	
Audio Frequency Conducted Susceptibility	18.0	B	
Induced Signal Susceptibility	19.0	A	
Radio Frequency Susceptibility	20.0	S T	radiated susc. conducted susc.
Emission of RF	21.0	B	compliant with CAT M except of harmonics of 1090 MHz
Lightning Induced Transient Susceptibility	22.0	A2XXX	
Lightning Direct Effects	23.0	X	
Icing	24.0	X	
Electrostatic Discharge (ESD)	25.0	A	
* see chapter 5.6 for restrictions			

5.8. Software level

The software level for VT-01 has been determined to be

Level D:

Software whose anomalous behavior, as shown by the system safety assessment process, would cause or contribute to a failure of system function resulting in a minor failure condition for the aircraft.

5.9. Telecommunication specifications

Emission power: with central unit VT-0102-()-()-125 or system unit VT-0104-125: 250 Watts max.
with central unit VT-0102-()-()-070 or system unit VT-0104-070: 200 Watts max.

Emission class: 12M0M1D

Frequency: 1090 MHz

5.10. Logic of on-Ground interface

The transponder has an on-ground interface, which should be connected to your aircraft installation, if an adequate signal will be provided. The following table shows the system behaviour for different configurations and input at the interface

on ground configuration in Menu \ on ground switch settings	NO	YES
no on-ground switch present	airborne	-
on ground	-	on ground
airborne	-	airborne

on ground: system replies not to Mode-A/C and Mode-S "all-call" interrogations, squitters active
airborne: system replies to all interrogations, squitters active



Do not install a manual on ground switch in the cockpit of your aircraft. If no adequate on ground switch is provided in the airframe, leave the on ground input unconnected.

5.11.CAN-Bus interface

The system provides a CAN-Bus interface for communication between steering unit and central unit. A detailed description of the interface can be obtained by the manufacturer (for system integrators or OEMs only).

6. Aircraft installation

The VT-01 provides maximum levels of flexibility. Depending on the space in your cockpit you can have a single-block or two-block equipment installation. The two-block system requires a mounting kit/cradle (PN # VT-0103-1-(-)-()) to carry the central unit. It allows a quick installation and removal of the complete central unit without using tools. If each aircraft in a fleet carries a steering unit and a mounting cradle, the central unit can be interchanged between all aircraft. All aircraft related data is stored in the steering unit, which always remains in an aircraft.



General: All installation work shall be performed in accordance with the acceptable methods, techniques and practices for aircraft alterations, inspections and repair, shown in FAA documents AC 43.13-1B and AC 43.13-2A (see www.faa.gov to obtain this documents free of charge in digital form).

6.1. Installation VT-01 - single-block

To install as a single-block system, the following steps need to be performed:

6.1.1. Assembling the steering unit and central unit:



Before attaching the steering unit to the central unit, Check if the pressure connector, the steering unit plug and the central unit plug are clean. If not, remove all foreign bodies from the parts.

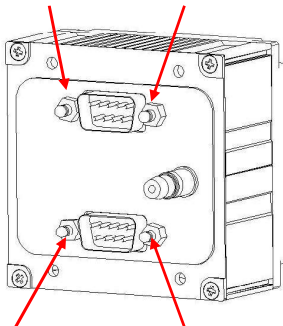

Rear view of steering unit

Replace the Quicklock terminals in the back of the steering unit with screws (4-40), if installed.

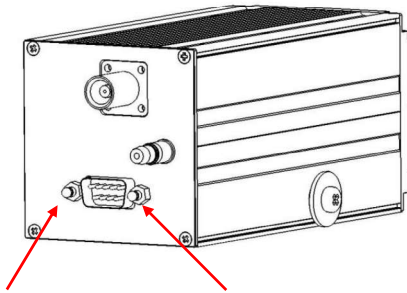

Rear view of central unit

Replace the screws (4-40) in the back of the central unit with quicklock terminals, if installed

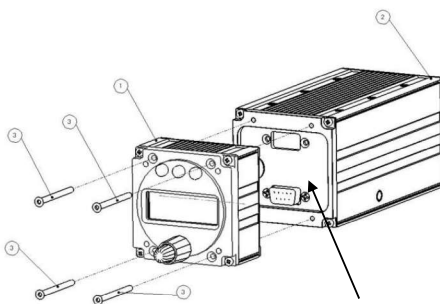

Front of central unit

1. Assemble mating pressure connector and plug for both units in the correct orientation
2. Push the steering unit (1) onto the central unit (2) . Use the 4 screws (3) to fasten both units.

6.1.2. Panel mounting

Determine a suitable position in the instrument panel that is in view of the pilot in command.

When choosing a position for installation, always be sure not to damage structural devices of the airframe.

Cut a 57mm (2 ¼ inch) diameter hole with 4 x 4.1mm holes for the mounting screws (see chapter 15 for detailed locations). A minimum space of 65.5mm x 65.5mm behind the panel cut out is required for clearance with adjacent instruments. A depth of 205mm is recommended to accommodate the transponder and electrical connectors.

6.1.3. Static pressure connection

The system contains an integral alticoder. Connect the static pressure line of the aircraft to the connector on back of the central unit.

The integral alticoder supplies data immediatly after switching on the VT-01. No warm up period is required. For calibration of the internal alticoder, an instruction will be provided by the manufacturer to qualified installers.

6.1.4. Wiring



Wiring electrical components shall be performed by qualified personal only to prevent damages and hazardous situations that could result in loss of life.
All wires (except the antenna line) related to the VT-01 in single-block configuration are connected to one SUB-D 9 pin connector on the back of the central unit.

Ensure that the Sub-D connector is fastened to the housing of the central unit correctly before operating the unit in flight.

The following subchapters describe the different lines required for operating the transponder.



DO NOT POWER ON THE TRANSPONDER WITH THE ANTENNA DISCONNECTED !!!

Damage to the RF unit caused by a disconnected antenna can be determined by the manufacturer and is not covered by the manufacturers warranty.

6.1.4.1. Connector wiring

Wire the female plug to be connected to the connector (CN3) on the back of the central unit as described in the following table. Refer to chapter 17 for a proper cable installation and assembling of the connector.

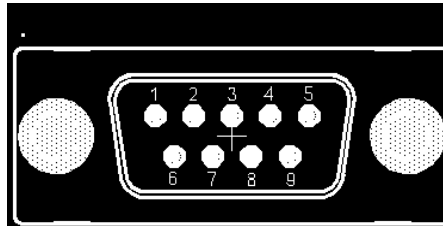

viewed from the back of the SUB-D 9 female connector

Pin	Function	Additional Information
1	+9V - + 28V DC	Connect to aircraft primary power source
2	mutual suppression	Connect to DME suppression bus (use shielded line)
3	RS-232 RX	For ADS-B (Data in)
4	CAN-LO	Not used in single-block installation, terminate as shown below
5	GND	Connect to common GND of airframe
6	Pwr_enable	Not used in single-block installation, do not connect
7	On Ground	Do not connect, if no on-ground signal is provided by aircraft installation
8	CAN-HI	Not used in single-block installation, terminate as shown below
9	GND	Connect to common GND of airframe

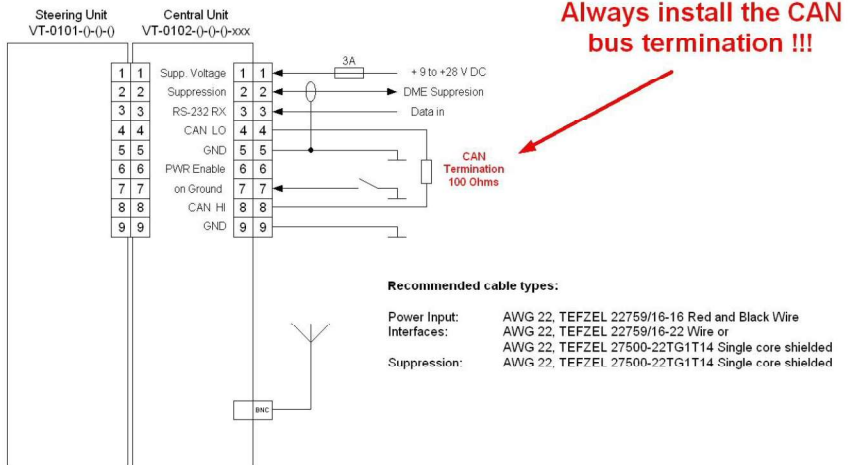

6.1.4.2. Power supply

The transponder is supplied by the aircraft's primary power source (10 V to 28 V DC). The system provides protection against reverse polarity. **Always install a Fuse !!!**

6.1.4.3. Suppression interface

The suppression line needs to be wired to other avionics components working in the 962..1213 MHz frequency band, such as DME or TACAN, to suppress any replies from the transponder that void the capability of such systems while operating.

The suppression line provides IN and OUT capability to prevent data transmission either to the transponder or other equipment.



Wiring the suppression line requires a qualified avionics technician or engineer to prevent any kind of malfunction of the installed equipment. All equipment connected to the suppression line must be re-inspected and re-approved before operation. Refer to chapter 5 for specifications of the suppression interface.

6.1.4.4. On-ground interface

If your aircraft installation provides an on-ground signal, it should be connected to this pin. The transponder replies only to discretely addressed Mode-S interrogations if the on-ground signal is present. The permanent emission of squitters will not be effected. Refer to chapter 5.10 for logic table of this interface.

6.1.4.5. RS-232 interface

This interface is intended for ADS-B applications. It may be used for connecting a GPS receiver to broadcast the current position with extended squitters.

Minimum recommended NMEA sentences are \$GPRMC, \$GPGGA, \$GPGSA. The baud rate is 4800 bps.

6.1.4.6. CAN-Bus interface



The CAN-Bus interface is used for communication between steering unit and central unit. If the one-block configuration will be installed, a resistor (100 ohms) must be used for proper termination of the bus. A missing termination results in COMM error and malfunction of the system.

For pinout refer to the wiring diagram shown on the previous page.

6.1.4.7. Antenna connection

Connect the BNC plug of the antenna line to the connector in the back of the central unit. Be sure that the plug has been fastened to prevent disconnection caused by vibration



DO NOT POWER ON THE TRANSPONDER WITH THE ANTENNA DISCONNECTED !!!

Damage to the RF unit caused by a disconnected antenna can be determined by the manufacturer and is not covered by the manufacturer's warranty.

Refer to chapter 9 for details about installing a transponder antenna in your aircraft.

6.2. Installation VT-01 - two-block

To install as a two-block system, the following steps need to be performed:

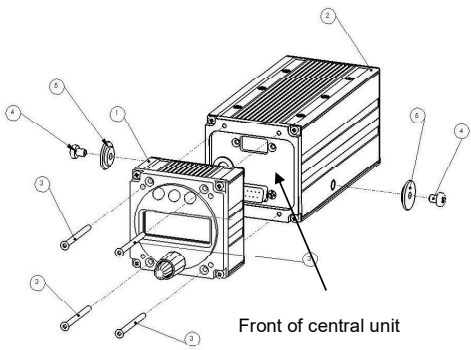
 <p style="text-align: center;">Front of central unit</p>	<p>Unfasten the 4 Screws (3) and remove the steering unit (1) from the central unit (2).</p>
--	--

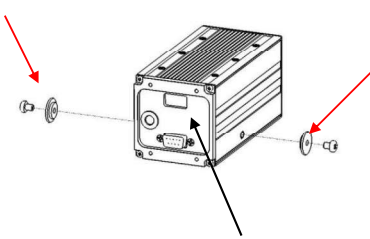
 <p style="text-align: center;">Front of central unit</p>	<p>Fasten a shoulder washer (5) with screws (4) on each side of the central unit.</p>
--	---

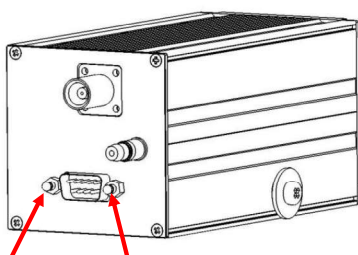
 <p style="text-align: center;">Rear view of central unit</p>	<p>Replace the quick lock terminals in back of the central unit with screws.</p>
--	--

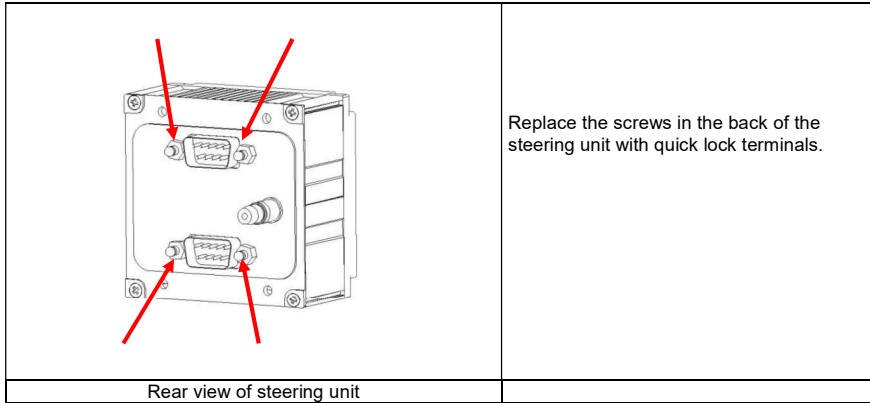

6.2.1. Installing the mounting kit / cradle

Select a suitable place for installation of the mounting kit / cradle (P/N # VT-0103-1-()-()) in your aircraft. Consider the space needed for inserting / removing the central unit. In order to remove make sure it is possible to reach and operate the lock device on the end of the cradle .

The maximum distance between steering unit and central unit is limited by the data interface cable used for communication between the system. It shall not exceed 10 metres in length.

Fasten the mounting kit to the airframe using 4 x M4x5 screws

6.2.2. Panel mounting

Determine a suitable position in the instrument panel that is in view of the pilot in command.

When choosing a position for installation, always be sure not to damage structural devices of the airframe.

Cut a 57mm (2 ¼ inch) diameter hole with 4 x 4.1mm holes for the mounting screws (see chapter 15 for detailed locations). A minimum space of 65.5mm x 65.5mm behind the panel cut out is required for clearance with adjacent instruments. A depth of 50mm is recommended to accommodate the steering unit and electrical connectors.

6.2.3. Static pressure connection

The steering unit contains an integral altimeter. Connect the static pressure line of the aircraft to the connector on back of the steering unit.

The integral altimeter supplies data immediately after switching on the VT-01. No warm up period is required. For calibration of the internal altimeter, an instruction will be provided by the manufacturer to qualified installers.

6.2.4. Wiring



Wiring electrical components should be performed by qualified personal only to prevent damages and hazardous situations that could result in loss of life.

All wires (except antenna line) related to the VT-01 in two-block configuration are connected to several SUB-D 9 pin connectors in the back of the steering unit and the central unit. Ensure that the Sub-D connectors are fastened to the housing of the central unit or steering unit correctly before operating the unit in flight.

The following subchapters describe the different lines required for operating the transponder.



DO NOT POWER ON THE TRANSPONDER WITH THE ANTENNA DISCONNECTED!!!

Damage to the RF unit caused by a disconnected antenna can be determined by the manufacturer and is not covered by the manufacturers warranty.

6.2.4.1. Connector wiring (CN1)

CN1 is used as the main connector for the aircraft installation. All signals/lines listed in the following table need to be connected to CN1.

<p style="text-align: right;">CN 1</p>	<p>CN1: Use for connecting the following signals/lines:</p> <ul style="list-style-type: none"> • Power • GND • Suppression • On ground • RS-232 (for ADS-B)
<p>Rear view of steering unit</p>	

Wire the female SUB-D 9 plug to be connected to CN1 (back of the steering unit) as described in the following table. Refer to chapter 17 for a proper cable installation and assembling of the connector.

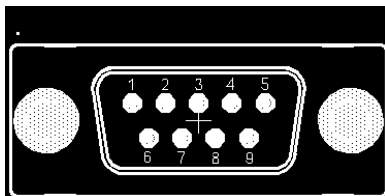

viewed from back of SUB-D 9 female connector

Pin	Function	Additional Information
1	+10 V to + 28V DC	Connect to aircraft primary power source
2	Suppression	Connect to DME suppression bus (use shielded line)
3	RS232 RX	For future application (Data in)
4	CAN-LO	Terminate as shown next page
5	GND	Connect to common GND of airframe
6	Pwr_enable	do not connect
7	On Ground	Do not connect, if no on-ground signal is provided by aircraft installation
8	CAN-HI	Terminate as shown next page
9	GND	Connect to common GND of airframe

6.2.4.2. Wiring the connection between the steering unit and the central unit

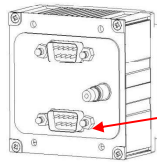

CN 2

CN2: Use for connecting to the central unit via connector of the mounting kit. Perform a 1:1 connection to the cradle connector:

- Power
- GND
- Suppression
- On ground
- RS-232 (for ADS-B)
- CAN-Bus

Back of steering unit

Wire the female SUB-D 9 plug to be connected to CN2 (back of the steering unit) to the cable leading to the cradle as described in the following table.

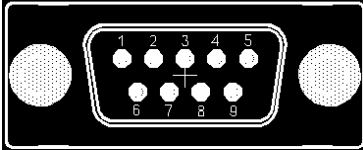

Pin	Function
1	+10V to +28V DC
2	Suppression
3	RS232 RX
4	CAN-Low
5	GND
6	Pwr_enable
7	On Ground
8	CAN-High
9	GND

viewed from back of SUB-D 9 female connector

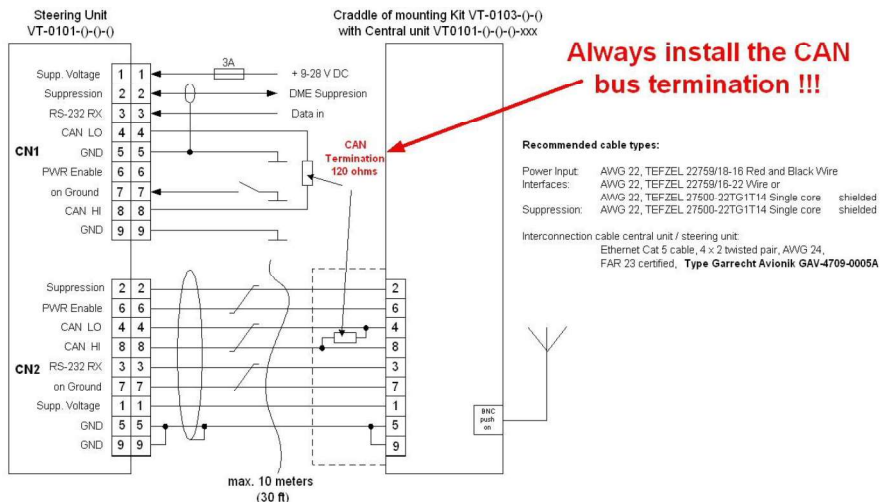

6.2.4.3. Power supply

The transponder is supplied by the aircraft's primary power source (10 V to 28 V DC). The system provides a protection against reverse polarity. **Always install a fuse !!!**

6.2.4.4. Suppression interface

The suppression line needs to be wired to other avionic components such as DME or TACAN to suppress any replies from the transponder that void capability of such systems while operating. The suppression line provides IN and OUT capability to prevent data transmission either to the transponder or to other equipment.



Wiring the suppression line requires a qualified avionic technician or engineer to prevent any kind of malfunction of the installed equipment. All equipment connected to the suppression line must be re-inspected and re-approved before operation. Refer to chapter 5 for specifications of the suppression interface.

6.2.4.5. On-ground interface

If your aircraft installation provides an on-ground signal, it should be connected to this pin. The transponder replies only to discretely addressed Mode-S interrogations if the on-ground signal is present. The permanent emission of squitters will not be effected. Refer to chapter 5.10 for logic table of this interface.

6.2.4.6. RS-232 interface

This interface is intended ADS-B applications. It may be used for connecting a GPS receiver to broadcast the current position in the squitters.

Minimum recommended NMEA sentences are \$GPRMC, \$GPGGA, \$GPGSA. The baud rate is 4800 bps.

6.2.4.7. CAN-Bus interface



The CAN-Bus interface is used for communication between steering unit and central unit. If the two-block configuration will be installed, on each device a resistor (120 Ohms) must be used for proper termination of the data bus. A missing termination results in COMM-Error and malfunction.

For pinout refer to the wiring diagram shown on the previous page.

6.2.4.8. Antenna connection

Connect the antenna line to the connector in the cradle. When inserting the central unit into the cradle, the antenna plug fits into the antenna socket of the cradle.



DO NOT POWER ON THE TRANSPONDER WITH THE ANTENNA DISCONNECTED!!!

Damage to the RF unit caused by a disconnected antenna can be determined by the manufacturer and is not covered by the manufacturers warranty.

6.2.5. Cradle handling

6.2.5.1. Inserting the central unit into the cradle

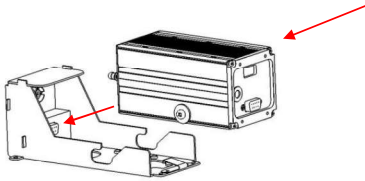

Insert the central unit with the antenna connector first in to the cradle.

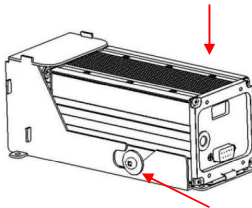

The shoulder washer will slide into the slots in the left and right wall of the cradle.

Then, press the central unit down and

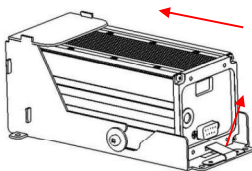

Move it into the direction of the antenna connector . If inserted correctly, the spring lock will flip up.

6.2.5.1.1. Removal of the central unit form the cradle

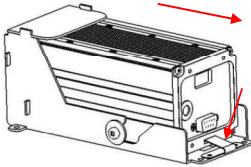

Press the spring lock down and pull the central unit into the direction of the spring lock.

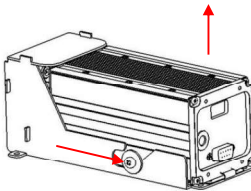

When the shoulder washer contact the wall of the slots in the left and right side of the cradle's wall, move the central unit up and

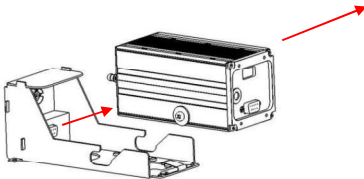

take it out of the cradle.

6.3. Installation VT-01 UltraCompact

The VT-01 UltraCompact is a very compact size unit with a low weight, that allows installation in small cockpits.

General: All installation work shall be performed in accordance with the acceptable methods, techniques and practices for aircraft alterations, inspections and repair, shown in FAA documents AC 43.13-1B and AC 43.13-2A (see www.faa.gov to obtain this documents free of charge in digital form).

6.3.1. Panel mounting

Determine a suitable position in the instrument panel that is in view of the pilot in command.

When choosing a position for installation, always be sure not to damage structural devices of the airframe.

Cut a 57mm (2 ¼ inch) diameter hole with 4 x 4.1mm holes for the mounting screws (see chapter 15 for detailed locations). A minimum space of 62 mm x 62 mm behind the panel cut out is required for clearance with adjacent instruments. A depth of 205mm is recommended to accommodate the transponder and electrical connectors.

6.3.2. Static pressure connection

The system contains an integral alticoder. Connect the static pressure line of the aircraft to the connector on back of the central unit.

The integral alticoder supplies data immediatly after switching on the VT-01. No warm up period is required. For calibration of the internal alticoder, an instruction will be provided by the manufacturer to qualified installers.

6.3.3. Wiring



Wiring electrical components shall be performed by qualified personal only to prevent damages and hazardous situations that could result in loss of life.

All wires (except the antenna line) related to the VT-01 in single-block configuration are connected to one SUB-D 9 pin connector on the back of the central unit.

Ensure that the Sub-D connector is fastened to the housing of the central unit correctly before operating the unit in flight.

The following subchapters describe the different lines required for operating the transponder.



DO NOT POWER ON THE TRANSPONDER WITH THE ANTENNA DISCONNECTED !!!

Damage to the RF unit caused by a disconnected antenna can be determined by the manufacturer and is not covered by the manufacturers warranty.

6.3.3.1. Connector wiring

The VT-01 UltraCompact comes with a prewired connector. Anyway, if modifications on this connector are required or a new connector should be needed, follow the instructions of this chapter

Wire the female plug to be connected to the connector (CN3) on the back of the central unit as described in the following table.

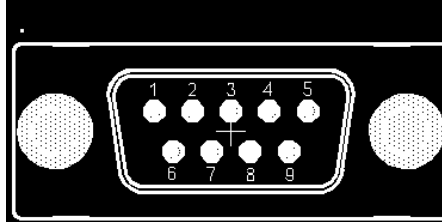

viewed from the back of the SUB-D 9 female connector

Pin	Function	Additional Information
1	+9V - + 28V DC	Connect to aircraft primary power source
2	mutual suppression	Connect to DME suppression bus (use shielded line)
3	RS-232 RX	For ADS-B (Data in)
4	CAN-LO	Not used in single-block installation, terminate as shown below
5	GND	Connect to common GND of airframe
6	Pwr_enable	Not used in single-block installation, do not connect
7	On Ground	Do not connect, if no on-ground signal is provided by aircraft installation
8	CAN-HI	Not used in single-block installation, terminate as shown below
9	GND	Connect to common GND of airframe

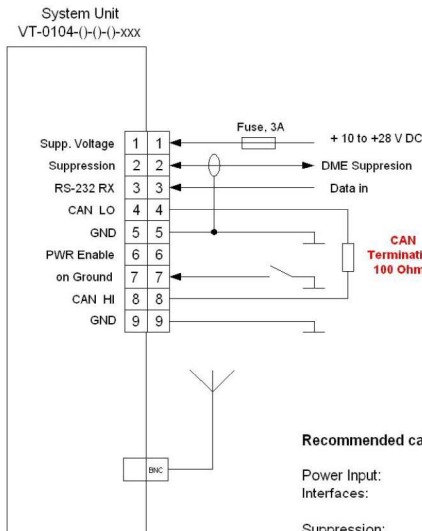

Always install the CAN bus termination !!!

Recommended cable types:

- Power Input: AWG 18, TEFZEL 22759/16-18 Red and blue wire
- Interfaces: AWG 24, TEFZEL 22759/16-24 Wire or AWG 22, TEFZEL 27500-22TG1T14 Single core shielded
- Suppression: AWG 22, TEFZEL 27500-22TG1T14 Single core shielded

6.3.3.2. Power supply

The transponder is supplied by the aircraft's primary power source (10 V to 28 V DC). The system provides protection against reverse polarity. **Always install a Fuse !!!**

6.3.3.3. Suppression interface

The suppression line needs to be wired to other avionics components working in the 962.1213 MHz frequency band, such as DME or TACAN, to suppress any replies from the transponder that void the capability of such systems while operating.

The suppression line provides IN and OUT capability to prevent data transmission either to the transponder or other equipment.



Wiring the suppression line requires a qualified avionics technician or engineer to prevent any kind of malfunction of the installed equipment. All equipment connected to the suppression line must be re-inspected and re-approved before operation. Refer to chapter 5 for specifications of the suppression interface.

6.3.3.4. On-ground interface

If your aircraft installation provides an on-ground signal, it should be connected to this pin. The transponder replies only to discretely addressed Mode-S interrogations if the on-ground signal is present. The permanent emission of squitters will not be effected. Refer to chapter 5.10 for logic table of this interface.

6.3.3.5. RS-232 interface

This interface is intended for ADS-B applications. It may be used for connecting a GPS receiver to broadcast the current position with extended squitters.

Minimum recommended NMEA sentences are \$GPRMC, \$GPGGA, \$GPGSA. The baud rate is 4800 bps.

6.3.3.6. CAN-Bus interface



The CAN-Bus interface is used for communication between steering unit and central unit. If the one-block configuration will be installed, a resistor (100 ohms) must be used for proper termination of the bus. A missing termination results in COMM error and malfunction of the system.

For pinout refer to the wiring diagram shown on the previous page.

6.3.3.7. Antenna connection

Connect the BNC plug of the antenna line to the connector in the back of the central unit. Be sure that the plug has been fastened to prevent disconnection caused by vibration



DO NOT POWER ON THE TRANSPONDER WITH THE ANTENNA DISCONNECTED !!!

Damage to the RF unit caused by a disconnected antenna can be determined by the manufacturer and is not covered by the manufacturer's warranty.

Refer to chapter 9 for details about installing a transponder antenna in your aircraft.

7. Antenna installation

7.1. General

Any type of suitable transponder antenna may be used for connection to VT-01.

Antenna installation should be done by qualified personal only. It is strongly recommend to follow the step by step instruction below:



- Generally, follow the instructions of FAA AC 42.13-2B regarding antenna installation.
- Select a suitable position for installing the antenna. The manufacturer of your aircraft should give you detailed information regarding this issue.
- Mount the transponder antenna as described by the antenna manufacturer.
- To prevent damages by moisture, seal all antenna mounts.



- When choosing a position for installation, always be sure not to damage structural devices of the airframe.
- For antenna installation in pressurized aircraft, follow the special instructions of FAA AC 42.13-2B.

7.2. Special instructions for antenna installation in composite aircraft

7.2.1. Mounting Preparation

The electrical bonding of the antenna to the aircraft ground is extremely important. If this is not done properly, antenna performance characteristics may become distorted and nulls may appear in the antenna radiation pattern. This, in turn, may cause erratic navigational readings or signal drop out. The electrical bonding of antennas to composite aircraft is best accomplished by direct metal-to-metal contact of the antenna mounting hardware to an internal ground plane. To do this, you must have the mounting screws, washers and nuts make direct contact to the internal ground plane with the use of a backing plate. The backing plate must make direct contact to the internal ground plane. Sandwich the aircraft skin and internal ground plane between the antenna base plate and internally mounted backing plate. To test the electrical bonding of the blade to the aircraft, a reading of .003 ohms between the antenna base plate and ground should be achieved.

7.2.2. Ground Plane Size

UHF antennas will require a metal ground plane size of 24" by 24" OR LARGER. "As large as practical" will assure optimum antenna performance. Most other antennas may also use the 24" by 24" rule, but with ground planes, larger is always better. After installation, double check that a reading of .003 ohms between the antenna base plate and ground has been achieved.

8. Antenna cable

The antenna line connects the RF connector of the transponder to the antenna. For a proper installation, it is recommended to follow the instructions below:

- Follow the instructions of the cable and plug manufacturer
- For a proper installation, avoid shorts and cable interruptions in the antenna line
- For the most type of installation, a special aircraft grade cable need to be used.

Do not exceed the maximum cable lengths specified below:

Class 1 instruments with 125 Watt @ antenna (central unit P/N: VT-0102-()-()-125 or system unit P/N: VT-0104-125)

Cable Type	Maximum length [m]	Maximum length [ft]
RG 58 C/U*:	3,6	11,5
RG 213*:	6,0	19,6
RG 400:	3,2	10,0
AIRCELL 7 *	6,0	19,6

* = not certified for aircraft installation

Class 2 instruments with 70 Watt @ antenna (central unit P/N: VT-0102-()-()-070 or system unit central unit P/N: VT-0104-070)

Cable Type	Maximum length [m]	Maximum length [ft]
RG 58 C/U*:	3,6	11,5
RG 213*:	6,0	19,6
RG 400:	3,2	10,0
AIRCELL 7 *	6,0	19,6

* = not certified for aircraft installation



The tables above are showing several antenna cable types and it's maximum lengths for reference only.

If other cable lengths or types should be used, be sure not to exceed a maximum loss of 2.5 dB. For connectors in the antenna line assume a loss of 0,2 dB /each.



Please always check, if certified cable is required for the installation in your aircraft.

9. Post installation configuration and setup

9.1. Setting up pilot specific data

9.1.1. Flight ID / aircraft registration

A Mode-S transponder broadcasts the flight id (company callsign for commercial aircraft or the aircraft registration for smaller private operated aircraft).



The flight id may be changed if required. Usually the FID is the callsign of your aircraft unless field 7 of the flight plan contains other data. **Always check before each flight if your flight id has been set correctly.**

If the transponder is operated in several aircraft with installed cradles then the steering units (usually installed in the instrument panel) need to remain in the same aircraft. The steering unit carries the flight id. So no changes are required, when moving the central unit to another aircraft.

Follow these steps to set the flight id / aircraft registration:

- Set the unit to standby (SBY) mode
- Press the on/off key and hold it. Press the mode key within 3 seconds.
- The current flight id will be shown on the screen now.

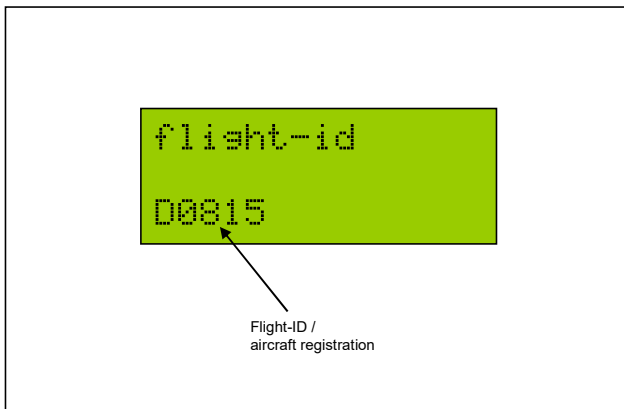

- To modify the flight id, press the inner knob of the double shaft rotary encoder. The underlined first digit of the flight id indicates the edit mode.
- Use the outer knob of the rotary encoder to select the position to be modified. Use the inner knob of the rotary encoder to modify the selected value. Do not enter dashes or blanks even when used in your aircraft registration or company callsign. The data must be entered left aligned.
- To finish editing the flight id press the inner knob of the rotary encoder.
- Exit the flight id page by pressing the mode key.

9.1.2. Display contrast



- Check, if the transponder antenna has been connected to the device properly
- If so, switch on the unit by pressing key 1
- If the BITE (build in self test) has been performed successfully, the system is ready for the next steps.
- Enter the installation setup by simultaneously pressing key 1 and the push button of the rotary encoder.

The screen shows as follows:

	<p>Use the outer knob of the rotary encoder to select the desired submenu.</p>
	<p>Sets the basic value for the LCD contrast. Additionally, the system provides an automatic temperature dependent contrast control. To modify the value, press the inner button of the rotary encoder and use the inner encoder to set up the desired values.</p>

9.1.3. Display illumination

The next screen shown is the illumination set up

	<p>Possible values:</p> <p>on LCD backlight and button illumination on, automatic brightness control by ambient light sensor</p> <p>off LCD backlight and button illumination always off.</p> <p>Press the inner knob of the rotary encoder and rotate it to set up the desired values.</p>
--	---

This menu will be shown only if the unit provides an illuminated display.

9.2. Setting up password protected data

The input fields for aircraft related data (such as 24-bit Mode-S or aircraft maximum speed) address is password protected to prevent unwanted modifications by unauthorised persons.

The password for this set up area is 10795C

Here are step by step instructions for entering the Mode-S address and other aircraft related data.



- Check, if the transponder antenna has been connected to the device properly
- If so, switch on the unit by pressing key 1.
- If the BITE (built in self test) has been performed successfully, the system is ready for the next steps.
- If no valid Mode-S address has been entered, skip the messages by pressing the inner knob of the rotary encoder.

Always set the device into the <SBY> mode, if you want to modify the settings in this menu.

- Enter the installation set up by simultaneously pressing key 1 and the push button of the rotary encoder.
- Enter the password shown above. If entered correctly, rotate the outer knob to navigate through the different menus as shown in this chapter.
- Press the inner knob of the rotary encoder to enter or edit the selected menu. The edit mode will be indicated by underlining the first character of the menu entry.
- An entered password remains active until switching off and on the unit.

9.2.1. Illumination

The first submenu shown in the password protected area is the illumination set up. Refer to par. 9.1.2 to learn how to set up the illumination of the device. This setting is possible in the unprotected and password protected mode. This menu will be shown only, if the unit provides an illuminated display.

9.2.2. LCD contrast

The second submenu shown in the password protected area is the LCD contrast set up. Refer to par. 9.1.3 to learn how to set up the illumination of the device. This setting is possible in the unprotected and password protected mode.

9.2.3. Power-up Mode

The third submenu shown contains the settings for the power up mode. Here you can define, in which mode the system should start, if power will be supplied to the main of the device (i.e. by the avionics main switch).

To select the desired value, follow these steps:

- Press the inner knob of the double shaft rotary encoder to invoke the edit mode
- Rotate the inner knob of the double shaft rotary encoder to select the desired value. Entering a certain value manually is not possible. Please use the values suggested by the system.
- To finish editing the settings, press the push button of the rotary encoder.

	<p>Possible values:</p> <p>off:</p> <p>System remains switched off after applying electrical power.</p> <p>Standby:</p> <p>System powers up in standby mode after applying electrical power.</p>
---	--

9.2.4. Aircraft data

All aircraft related data of the following chapters are stored in a profile. If using the system in different aircraft (i.e. balloons), a special firmware feature provides up to five different profiles, that can be selected by the pilot before takeoff.

To enter the following submenu, press the inner knob of the rotary encoder, if the **acft data** menu item has been selected.

The screen shows

	<ul style="list-style-type: none"> • To change the profile selection, press the inner knob of the encoder and rotate it then to select the desired profile. • If the desired profile has been selected, press the inner knob of the rotary encoder again to finish the edit mode. Now, rotate the outer knob to view and change the settings of the selected profile, as shown in the following subchapters.
---	--



NOTE: If you have not purchased for the multiple Mode-S profile feature, only Profile-1 can be selected.

9.2.4.1. Aircraft address



A proper installation and operation of a Mode-S transponder requires the installer to set a unique 24 bit Mode-S Address, the aircraft maximum speed as well as the flight id or aircraft registration. The 24 bit Mode-S address needs to be obtained from your national aviation authority. Contact the department, where you got the aircraft registration from.



The first submenu shown in a profile contains the 24 bit address.

To modify the address, follow these steps:

- Press the inner knob of the double shaft rotary encoder. The underlined first digit of the 24-bit address indicates the edit mode.
- Use the outer knob of the rotary encoder to select the position to be modified. Use the inner knob of the rotary encoder to modify the selected value. Do not enter dashes or blanks. The data must be entered left aligned.
- To finish editing the 24-bit address, press the push button of the rotary encoder.
- Exit the flight id page by pressing the mode key.

A correct 24 bit Mode-S address is required for proper Mode-S operation. If no address has been entered, the system works as a Mode- A/C transponder.

In this case, the following messages appears in the startup screen:

 <p>Mode-S Addr: INVALID</p>	<p>confirm this message by pressing <Ident> or <Mode> or push button of rotary encoder</p>
 <p>running in A/C Mode</p>	<p>confirm this message by pressing <Ident> or <Mode> or push button of rotary encoder</p>

9.2.4.2. Flight ID

Here you can enter the flight ID corresponding to the aircraft address (Mode-S address). Refer to par. 9.1.1 to learn how to set up the flight ID. The flight ID entered in this menu can be overwritten by the pilot entering the unprotected area, if required.

9.2.4.3. Aircraft Maximum Speed (maxspeed)

This submenu shown contains the settings for the aircraft maximum speed.

This data needs to be set for communication with the TCAS system installed in larger aircraft. Consult your aircraft's flight manual to determine the required information.

To enter the desired value, follow these steps:

- Press the inner knob of the double shaft rotary encoder. The underlined first digit of the speed range shown on the screen indicates the edit mode.
- Use the inner knob of the double shaft rotary encoder to select the appropriate range for the aircraft the unit has been installed in. Entering a certain value manually is not possible. Please use the values suggested by the system.
- To finish editing the maximum speed, press the push button of the rotary encoder.
- If you do not know the aircraft maximum speed, please select <unknown>.

 <p>maxspeed <=75 kt</p>	<p>Possible values:</p> <p>unknown select this value, if no information is present for your aircraft</p> <p><= 75 kt</p> <p>76-150 kt</p> <p>151-300 kt</p> <p>301-600 kt</p> <p>601-1200kt</p> <p>>1200kt</p> <p>Note: The maximum speed the VT-02 is allowed to use for is 250 kts. Higher values are for reference only.</p>
--	--

9.2.4.4. Configuring on ground switch (auto-gnd)

The third submenu allows configuring the on ground switch input of the transponder. It needs to be configured, if the unit has been connected to an on-ground switch provided by the airframe.

- Press the inner knob of the double shaft rotary encoder. The underlined first digit on the screen indicates the edit mode.
- Use the inner knob of the double shaft rotary encoder to select the desired value. Set it to YES, if an airborne information will be provided by the aircraft and the transponder has been connected to this switch. Select NO, if no such switch is available in your aircraft. If no on ground switch is available in your airframe, the system broadcasts an "airborne" message permanently.
- To finish the edit mode press the push button of the rotary encoder.



If you do not know, if an external on-ground switch has been connected or works properly, please select **<no>** for the auto-gnd option.

To leave the configuration menu, press the <IDENT> button. Pressing the <MODE> button returns to the next higher menu level.

9.2.4.5. Alticoder set up

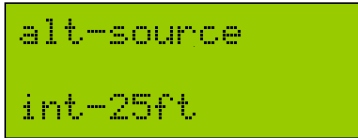

This menu can be activated only, if the system has been set into the <ALT> mode for at least 10 sec. after switching on and a firmware version of the main processor board unit is at least rel. 1.50.

	<p>Possible values:</p> <p>int-25ft uses the internal pressure sensor for alticoding with 25ft resolution.</p> <p>int-100ft uses the internal pressure sensor for alticoding with 100ft resolution.</p> <p>Other values are for future enhancements (e.g. external alticoder) and must not be selected.</p> <p>Press the inner button of the rotary encoder and use the inner encoder to set up the desired values.</p>
--	--

10. Determining installed equipment performance

In order to comply with EUROCAE ED-73B, it is required to determine equipment performance of the installed equipment.

The complete aircraft installation must be certified by authorized personal before operation.

10.1. Checking equipment installation

	passed
Accessibility Controls provided for in-flight operation shall be readily accessible from the operator's normal seated position. Displayed information shall be clearly viewable, without obstruction, from the normal seated position(s) of the appropriate operator/crew member(s).	<input type="checkbox"/>
Aircraft Environment Installed equipment shall be compatible with the environmental conditions present in the specific location in the aircraft where the equipment is installed.	<input type="checkbox"/>
Display Visibility Displays shall be readable from the crew members' normal position in all ambient light conditions for which the equipment is required.	<input type="checkbox"/>

10.2. Equipment performance

	passed
Reply Frequency Interrogate the installed transponder and verify that the reply frequency is 1090 MHz +- 1 MHz for both Class 1 and Class 2 equipment.	<input type="checkbox"/>
Transmitter Power Output a. Verify that Class 1 transponders have a peak pulse power at the antenna end of the transmission line of at least +21 dBW and not more than +27 dBW. b. Verify that Class 2 transponders have a peak pulse power at the antenna end of the transmission line of at least +18.5 dBW and not more than +27 dBW.	<input type="checkbox"/>
Receiver Sensitivity a. Verify that for Mode A/C interrogations the receiver sensitivity of the equipment at the antenna end of the transmission line is -73 dBm, ±4 dB. b. Verify that for Mode S P6 type interrogations the sensitivity of the equipment at the antenna end of the transmission line is -74 dBm, ±3 dB.	<input type="checkbox"/>
Pressure altitude transmissions Select the mode <ON> (internal alticoder disabled) and verify that (1) the transponder response to Mode C interrogations consists only of framing pulses F1 and F2, and (2) the transponder response to Mode S interrogations UF=4 and UF=20 contains all ZEROs in the AC field.	<input type="checkbox"/>

<p>Altitude Reporting test</p> <p>General: A sufficient number of test points should be checked to ensure that the altitude reporting equipment and transponder perform their intended function through their entire range while ascending or descending. Tests some altitude steps to ensure proper operation of each altitude code segment of the encoder.</p> <p>Verify that the correspondence error value of the altimeter system is 125 feet or less.</p> <p>Verify that exceeding 50.000 ft and -1.000 ft generates an out of range error message, if using the internal alticoder.</p> <p>Verify that exceeding 62.700 ft and -1.000 ft generates an out of range error message, if using external alticoders.</p> <p>If alticoder set to 100 ft resolution: Verify in all cases that the Q bit is set to 0.</p> <p>If alticoder set to 25 ft resolution: Verify in all cases that the Q bit is set to 1 for altitudes up to 50.170 ft. For altitudes above 50.170 ft, the Q bit must be set to 0.</p>	<p>passed</p> <p><input type="checkbox"/></p>
<p>Airspeed Fixed Field Interrogate the equipment to confirm the maximum airspeed report.</p>	<p><input type="checkbox"/></p>
<p>On-the-Ground Condition If a means for automatically indicating the on-the-ground condition (e.g. a weight on wheels or struct switch) is available:</p> <p style="padding-left: 40px;">Verify that the equipment correctly reports the "on-the-ground" condition in the CA, FS and VS fields.</p> <p style="padding-left: 40px;">Verify that the equipment correctly reports the "airborne" condition in the CA, FS, and VS fields.</p> <p>If a means for automatically indicating the on-the-ground condition (e.g. a weight on wheels or struct switch) is not available:</p> <p style="padding-left: 40px;">Verify that the FS and VS fields indicate that the aircraft is airborne and that the CA field indicates that the aircraft is either airborne or on the ground (CA=6).</p> <p>Also verify that when the unit is in the "inhibit replies" condition (on the ground), the transponder continues to generate Mode S squitters and replies to discretely addressed Mode S interrogations (UF=0,4,5,16,20,21,24), but does not reply to Mode A/C/S All-Call or Mode S-Only All-Call interrogations (some installations may inhibit Mode A/C).</p> <p>If the unit is not in the "inhibit replies" condition (Airborne condition), verify that the transponder continues to generate Mode S squitters and also replies to Mode A/C, Mode A/C/S All-Call or Mode S Only all Call and discretely-addressed Mode S interrogation (UF=0,4,5,16,20,21,24),</p>	<p><input type="checkbox"/></p>
<p>Aircraft Identification (AIS) Interrogate the equipment with UF=4 or 5, and correct aircraft address with RR=18 and DI 7 or DI=7 and RRS=0. Verify that the equipment correctly reports the AIS information in the MB field of the reply.</p>	<p><input type="checkbox"/></p>

10.3. Flight test procedures

10.3.1. General

This guidance material offers examples of flight test procedures for demonstrating selected performance functions. Flight demonstration of installed performance may be required to determine the performance and characteristics of the installed antenna.

If the aircraft has been equipped with a transponder before, the flight test after installing the VT-02 might be obsolete, if the following conditions are fulfilled:

- The rated RF output power of the old device was less or equal to the RF output power of the VT-02
- The antenna used for the VT-02 is the same as used before (NOTE: Replacing the old antenna by a new antenna of the same type is also sufficient to fulfil this requirement.
- If a new antenna line need to be installed, be sure, that the maximum loss of the new line does not exceed the loss of the old antenna line.

10.3.2. Flight tests instructions

For determining performance in flight, all tests on ground as shown in 10.1. need to be performed successfully.

Arrange a schedule with the area air traffic control facility so that a controller is available to observe the transponder reply and communicate with the test aircraft to confirm performance of the transponder.

- a. Select a test area such that line-of-sight signal propagation is ensured (distance: 60 nm to selected ATC facility).
- b. So that ATC can confirm valid returns through normal flight attitudes, test manoeuvres may include standard rate turns through 360 degrees, climbs and descents.
- c. Verification of Mode A codes selected, and reported altitude responses to Mode C should also be checked.
- d. Verify if ATC confirms valid replies with gear down (if applicable) and flaps set to landing configuration
- e. Verify, if interference with other electronic equipment installed in the aircraft occurs during the flight.

For detailed information regarding flight tests refer to document FAA AC 23-8B, Chapter 5.

11. Instructions for continued airworthiness

Other than for periodic functional checks required by the regulations, the VT-01 Mode S Transponder has been designed and manufactured to allow "on condition maintenance". This means that there are no periodic service requirements necessary to maintain continued airworthiness, and no maintenance is required until the equipment does not properly perform its intended function (i.e. indicated by the built-in test routines)

Repairs should only be carried out in accordance with Garrecht Avionik GmbH service procedures (CMM).

Appendix A - Dimensions

VT-01 Steering unit and System unit

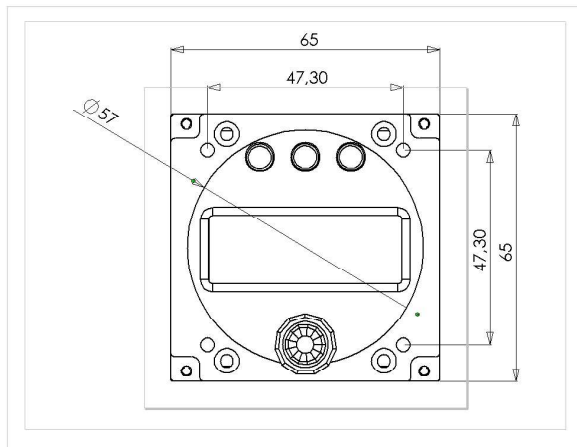
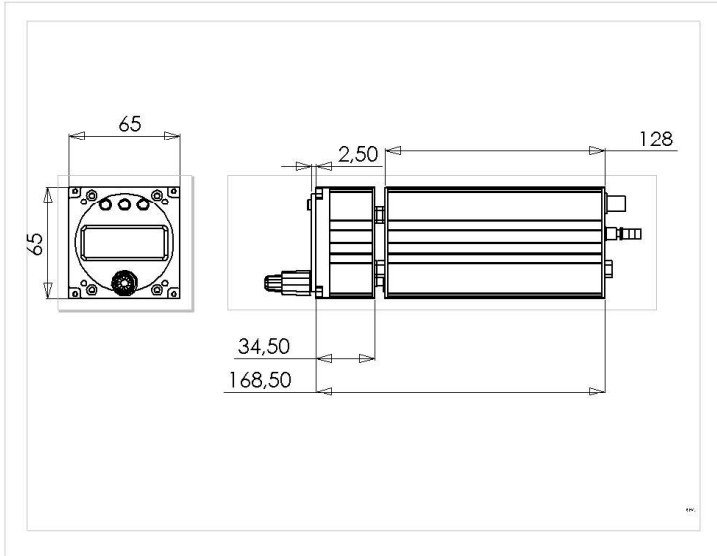

VT-01 Mounting kit (with cradle)

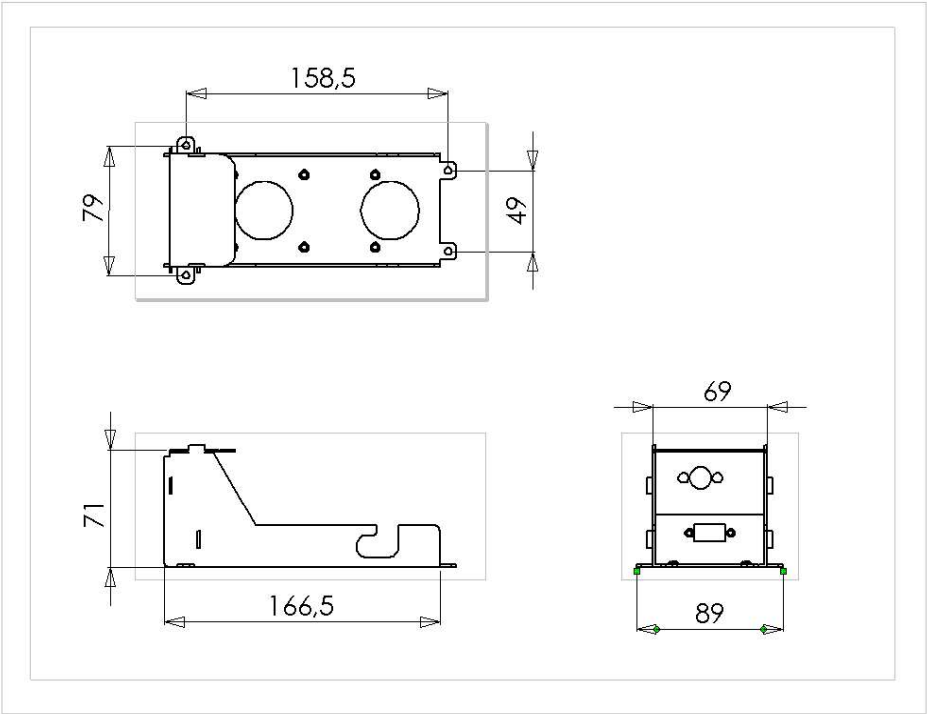

VT-01 UltraCompact

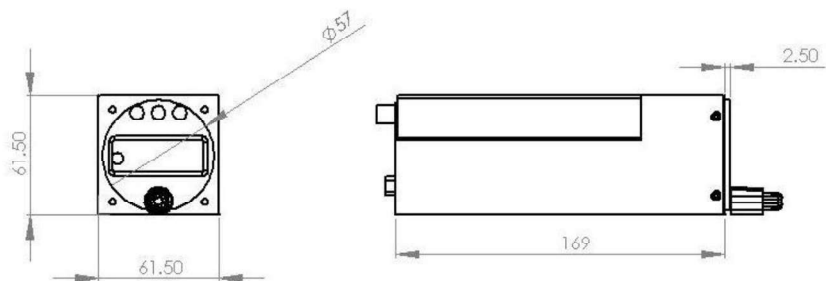

Appendix B

Template for panel cutout

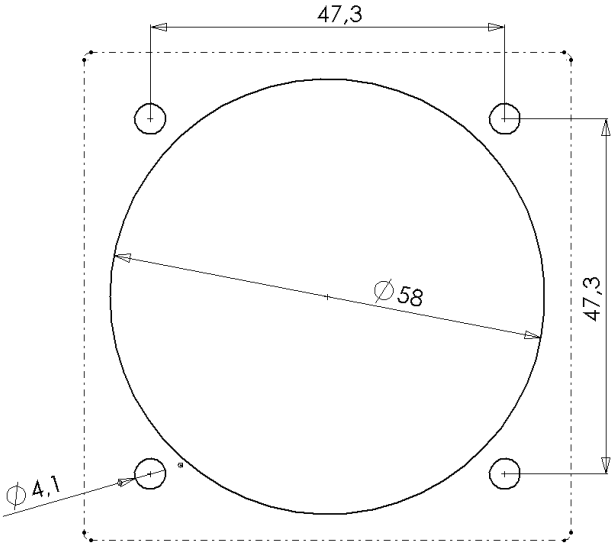

Appendix C

Assembling BNC/TNC plugs for AIRCELL 7 coaxial cable

1.

Cut the cable end perpendicularly

2.

Slip the nut, the pressure ring and the rubber gasket over the cable end.
Hint: With a small amount of vaseline the rubber gasket will slide more easily.

3.

Remove 8 mm of the PVC sheath from the end of the cable with a knife.

4.

Bend copper braid at 90 degrees to cable body. Push in contact ferrule between copper foil and braid until stop. Trim braid even to rim of ferrule. Slide rubber gasket down to the contact ferrule.

5.

Remove foil and dielectric with a knife.

6.

Slide teflon disk over center conductor. Insert center pin and solder carefully through the little hole.

7.

Slide teflon isolator on center pin.





8.

Slide the prepared cable end into the connector housing until stop. Tighten smoothly with two wrenches 16 mm so that there is still a small gap visible between the nut and the connector housing.

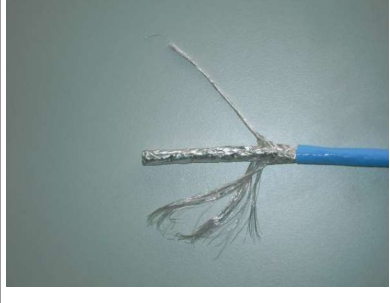
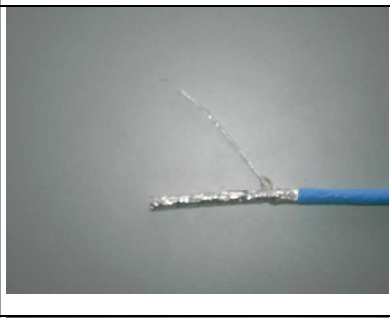
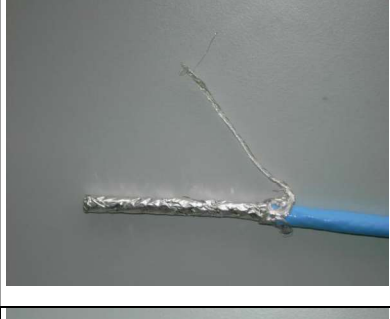
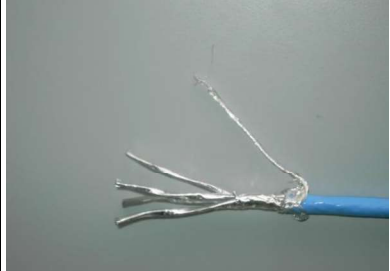
Assembling the Sub-D Connectors for interconnection wiring

For a proper shielding of the interconnection wiring, follow these steps:

	<ul style="list-style-type: none">• Remove the outer insulation of the interconnection cable (65mm/2.5")• Split the silver plated copper braid into two parts. Leave about 15mm/1.6" of the braid.• Twist one part of the braid to a wire.
	<ul style="list-style-type: none">• Cut the other part.
	<ul style="list-style-type: none">• Flip the remaining part of the braid over the outer insulation of the interconnection wire.
	<ul style="list-style-type: none">• Remove the conductive aluminium tape around the cable bundle. Leave about 15mm/1.6" of the tape.

	<ul style="list-style-type: none">• Flip the conductive aluminium tape braid, which has former been flipped over the outer insulation.
	<ul style="list-style-type: none">• Install the hood cable clamps as shown in this and the following picture
	
	<ul style="list-style-type: none">• Remove the shielding of each twisted pair.

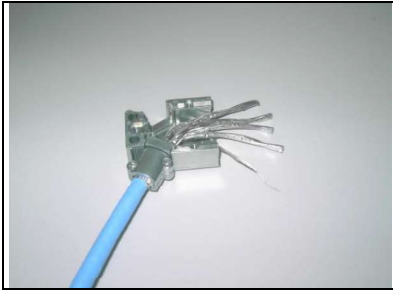

- Insert the cable with the cable clamp into the hood as shown.
- Cut all pairs and the wire made of the braid to appropriate length for installation of a Sub-D Connector (not shown in this picture). Always use shrink line when attaching the wires to the Connector.